

# Kolibri™

## Domino

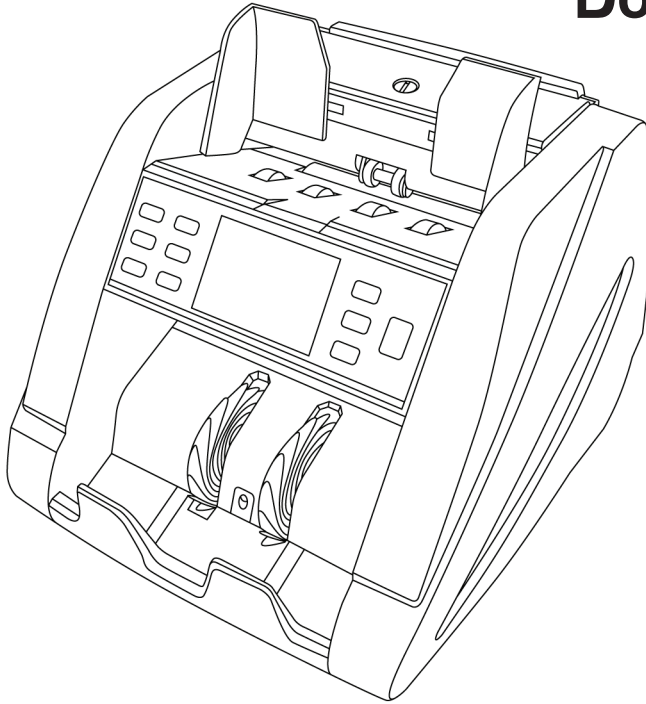

# USER MANUAL

Kolibri Domino One Pocket Currency Discriminator

This manual contains important information on safety measures and operational features of the Kolibri Domino one-pocket currency discriminator. Please read it carefully before operating your machine and keep it for future reference.

While every effort has been made to include all features into this user manual, specifications stated may not reflect all the features of the later software versions.

If you have questions about your Kolibri Domino and its operation, please contact technical support at [www.kolibriusa.com/contact/](http://www.kolibriusa.com/contact/)



**CHOKING HAZARD.  
SMALL PARTS**

Not for children under  
3 years old.



**WARNING: RISK OF  
ELECTRICAL SHOCK.**

This equipment is to be serviced  
by trained personnel only.



**DO NOT DISPOSE  
IN TRASH.**

Follow appropriate local  
electronics scrap procedures.



**WARNING: HAZARDOUS  
MOVING PARTS**

Do not place fingers, hair,  
clothes, lanyards...  
near moving parts.



**PROP 65 WARNING.** This product may contain chemicals known to the State of California to cause cancer, or birth defects or other reproductive harm.

<https://oehha.ca.gov/>

## Table of Contents:

<b>1. INTRODUCTION</b>	
1.1 About the Kolibri Domino	1
1.2 Important Safety Notes	1
1.3 Box Contents	2
1.4 Specifications	2
1.5 Views of the Kolibri Domino	3
1.6 Control Panel	4
1.7 Home Screen	5
<b>2. GETTING STARTED</b>	
2.1 Powering Up	6
2.2 Loading the Hopper	6
<b>3. OPERATING MODES</b>	
3.1 Mix Mode	8
3.2 Sort Mode	8
3.3 VSort Mode	9
3.4 Count Mode	9
<b>4. FUNCTIONS</b>	
4.1 Auto and Manual Function	10
4.2 Add Function	10
4.3 Batch Function	10
4.4 Add+Batch Function	11
<b>5. AFTER-COUNT FUNCTIONS</b>	
5.1 Report	11
5.2 Serial Report	11
5.3 Print	12
5.4 Menu	12
<b>6. MAINTENANCE AND TROUBLESHOOTING</b>	
6.1 Maintenance	13
6.2 Adjusting the Feed Gap	15
6.3 Calibration Procedure	17
6.4 Troubleshooting	18
6.5 Warranty	21
6.6 Contact Information	22

# 1. INTRODUCTION

## 1.1 About the Kolibri Domino

Thank you for choosing the Kolibri Domino one-pocket currency discriminator.

The Kolibri Domino is a professional, powerful, value counter and sorter.

Kolibri Domino has a convenient user-friendly interface, intuitive control panel, and a variety of counting modes. All of these features come with strong built-in counterfeit detection technology and high level performance.

## 1.2 Important Safety Notes

When using this product, basic safety precautions should always be followed, including the following:

- Do not use this product in areas where it may be exposed to water or any other liquids.
- Unplug this product from the wall outlet before cleaning. Use a damp cloth or air duster to clean the unit.
- To avoid the risk of electrical shock, do not disassemble this unit. Disassembling will expose you to dangerous voltages and other safety risks. Incorrect reassembly may cause electrical shock when the unit is subsequently used.
- Only use this product with the power cord supplied with the it. Plug the power cord into a properly grounded wall outlet. Do not remove the grounding pin from the power cord. Failure to properly ground the unit can result in severe injury or fire.
- Make sure the device is placed on a flat surface. Do not operate the unit in areas with high temperature, humidity or smoke as these conditions may impede performance.
- This product is designed for indoor use in a well-ventilated environment. Keep the unit away from direct sunlight and strong magnetic fields which may interfere with the counterfeit detection sensors.
- When not using the unit for an extended period of time, disconnect the power cord from the wall outlet.

### 1.3 Box Contents

- Kolibri Domino Currency Discriminator
- Adapter Cable (for Printer\*)
- Power Cord
- User Manual
- Cleaning Brush
- Calibration Card (White Paper Card)

*\*Printer sold separately*

### 1.4 Specifications

Counting speed: Adjustable 800, 1000 and 1200 bills/min

Hopper capacity: 500 bills

Stacker capacity: 200 bills

Weight: 12.8 lbs (5.8 kg)

Dimensions: 11.3" x 8.9" x 9.25" (287mm x 270mm x 235mm)

Power source: AC 100-240 V, 50/60Hz, ≤ 70W

## 1.5 Views of the Kolibri Domino

1. Feed Gap Adjustment Knob
2. Bill Guides
3. Hopper
4. Control Panel
5. TFT Screen
6. microSD Card Port
7. Stacker
8. Carrying Handle
9. Back Door
10. Back Door Handle
11. RJ11 Port (Printing)
12. USB Port
13. Power Switch
14. AC Power
15. Fuse

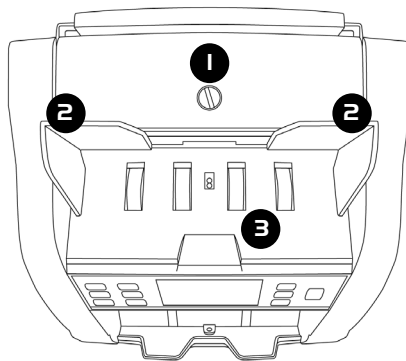

TOP VIEW

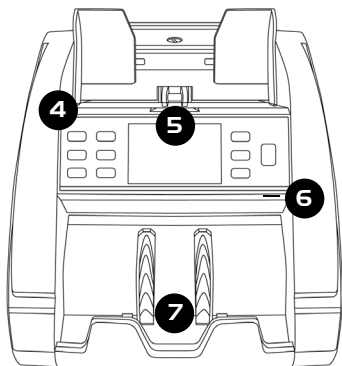

FRONT VIEW

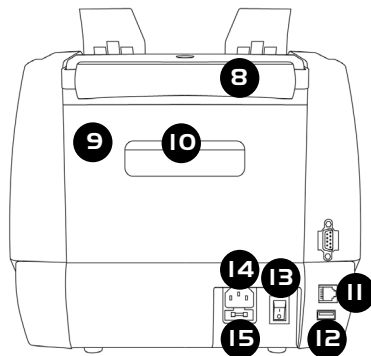

BACK VIEW

## 1.6 Control Panel

Key	Function
1. CUR Button	Changes currency type (USD, CAD, MXN)
2. BATCH Button	Activates/Deactivates Batch function
3. REPORT Button	Shows the detailed Report Screen (for Serial Report press REPORT button twice)
4. ADD Button	Activates/Deactivates Add function
5. +1/+10 Button	Customizes batch in increments of 1 or 10 (Press for +1, Hold for +10)
6. PRINT Button	Prints the displayed report if a printer is connected
7. Display	Shows total count and all settings (or shows all data)
8. MENU Button	Shows settings and works as a "back button" in Menu
9. MODE Button	Changes mode and moves cursor up in Menu
10. CLEAR Button	Resets the count and moves cursor down in Menu
11. START/STOP Button	Starts or Stops the count (when not in auto-start function) or validate/confirm settings

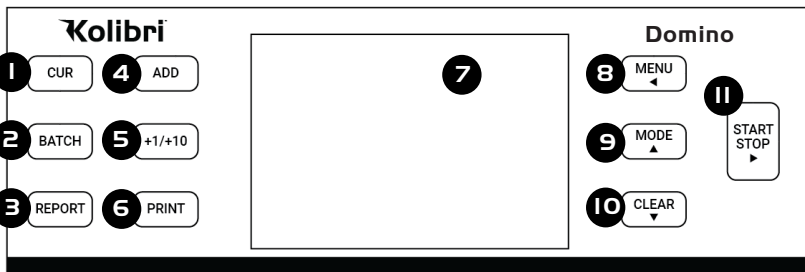

## 1.7 Home Screen

1. Currency Selected
2. Mode Selected
3. ADD Function (Activated)
4. Selected Batch Number (Activated)
5. Number of Bills Counted
6. Total Value Counted
7. Auto/Manual Start Function
8. Counterfeit Detection (ON)
9. Time
10. Date
11. Serial Number of Last Bill Scanned
12. Number of Rejected Bills

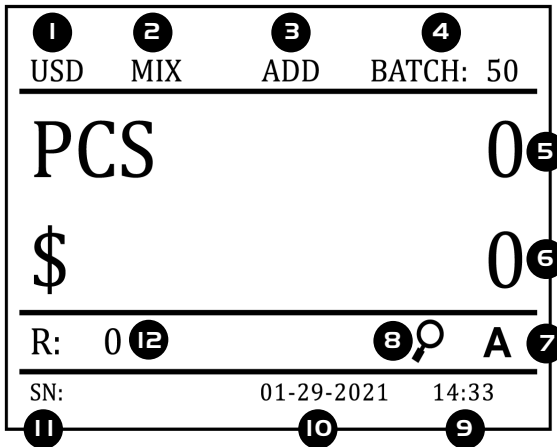

## 2. GETTING STARTED

### 2.1 Powering Up

Ensure the hopper and stacker are empty. Then, attach the provided power cable to the power inlet on the back of the machine. Make sure to plug the power cable into a three-prong outlet and turn on the power switch located on the back of the machine .

The unit will load and conduct a self-checking. When the home screen is displayed the machine is ready to operate.

### 2.2 Loading the Hopper

In order to avoid jams and ensure proper operating speed of the machine, it is important to correctly load the hopper. Bills should be placed in a neat stack prior to being placed into the hopper.

Avoid counting bills that are wet, excessively dirty, spoiled, folded, curled or with foreign material like clips, bands, etc. Bills such as these can cause the machine to malfunction.

Adjust the hopper bill guides to a size slightly wider (0.10" on each side) than the width of the bills in the stack (all US dollar denomination are the same size). This will help to correctly place the bills in the hopper, and will ensue smooth bill feeding.

**WARNING: Hazardous moving parts!**  
Do not place fingers, hair, clothes, etc. near the moving parts.

## TIPS: To Reduce Rejects

### 1. MAKE A STACK

Correct or remove bills that are severely wrinkled, damaged or folded. Square the bill stack.

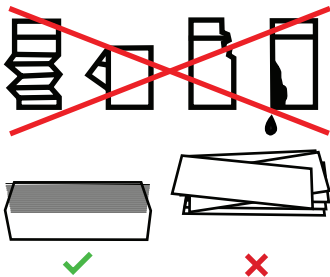

### 2. LOAD THE STACK

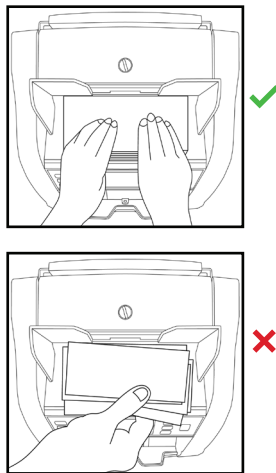

### 3. FEED THE BILLS

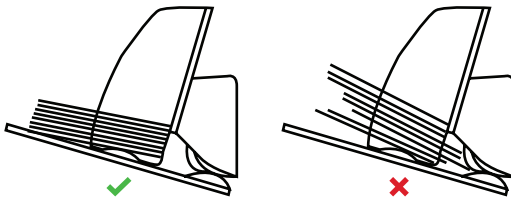

## 3. OPERATING MODES

### 3.1 Mix Mode

MIX mode is used to count a stack of mixed denominations. To count mixed bills, place them in the hopper and follow the procedure described in 2.2 LOADING THE HOPPER. The machine will start counting and will move the bills from the hopper to the stacker as it counts them. The machine will stop counting when the hopper is completely emptied. Total number of bills and total value will be displayed on home screen. When operation is complete, you can view a detailed report by pressing the REPORT button.

To return to MIX mode from another mode, press the MODE button until “MIX” is displayed on the home screen. Note that the Kolibri Domino will keep in memory the last mode used.

### 3.2 Sort Mode

This mode is available by pressing the MODE button until “SORT” is displayed on the home screen.

SORT mode allows the user to count and sort bills by one denomination which is automatically determined by the first bill scanned in a stack. This can be useful to be sure that there are no bills of other denominations in a large strap of one denomination. The first bill in the hopper determines the counting and sorting denomination. Any time a bill passes through the machine and does not conform to the denomination determined by the first bill, the machine will reject this bill, beep and a “DIFFERENT DENOMINATION” message will be displayed on the screen. Total number of bills and total value will be displayed on home screen. When operation is complete, you can view a detailed report by pressing the REPORT button.

To return to SORT mode from another mode, press the MODE button until “SORT” is displayed on the home screen. Note that the Kolibri Domino will keep in memory the last mode used.

### 3.3 VSort Mode

This mode is available by pressing the MODE button until “VSORT” is displayed on the home screen.

VSort mode allows the user to count a mixed stack of bills and separate them by denomination, similar to a cash register. This mode identifies the first bill in the hopper when Domino begins to count, and if a different denomination is detected, the machine stops and displays a message. The user must follow the instructions displayed on that message. Every time a denomination changes, the user must remove all bills from the stacker and separate them by denomination. When counting is finished, the user will have separated all bills into piles of each denomination. VSort by default works with ADD mode, allowing the user to keep track of the total number of bills along with the total value displayed on the home screen. When the operation is complete, the user can review a detailed report by pressing the REPORT button.

To return to VSort mode from another mode, press the MODE button until “VSORT” is displayed on the home screen. Note that Domino will keep in memory the last mode used.

### 3.4 Count Mode

This mode is available by pressing the MODE button until “COUNT” is displayed on the home screen.

COUNT mode allows the user to simply count the total number of bills. It does not recognize or record the denomination of any bills. During COUNT mode, there is no counterfeit detection active except ultraviolet.

*\*Detection can be turned ON or OFF manually in MENU under option 2. DETECTIONS\**

To return to COUNT mode from another mode, press the MODE button until “COUNT” is displayed on the home screen. Note that the Kolibri Domino will keep in memory the last mode used.

## 4. FUNCTIONS

### 4.1 Auto and Manual Function

After turning the machine on it will default to AUTO function, an “A” will be displayed on the home screen, machine starts counting automatically. To switch to the Manual function, go to Menu by pressing MENU button, select:

1. SETTINGS and press START/STOP button.
2. When in settings menu select 2. AUTO/MANUAL START by going down with the CLEAR button and press START/STOP to enter.
3. Select 2. MANUAL and press START/STOP button to validate selection, check mark will be displayed next to the selected function.
4. Press MENU button 3 times to go back to the home screen. If MANUAL is selected, a “M” will be displayed on the home screen.

If on Manual, Kolibri Domino will stop counting automatically and START/STOP button must be pressed to begin each count. To go back to Auto function repeat steps listed above and select AUTO function.

### 4.2 Add Function

This function is available by pressing the ADD button on the control panel. When ADD function is activated, an “ADD” will be displayed on the home screen.

ADD function allows the user to count multiple stacks of bills while keeping track of the total amount and value of bills counted. Place the first stack of bills to be counted in the hopper. The number and value of bills will be displayed on screen. When ready to count the next stack of bills, empty the stacker and add the new stack to be counted into the hopper. The unit will continue counting and add the new count to the total.

To exit ADD function, press again the ADD button.

### 4.3 Batch Function

This function is available by pressing the BATCH or +1/+10 button on the control panel. When BATCH function is activated, a “BATCH” icon with the batch number will be displayed on the home screen.

BATCH function is used to select a batch quantity for a specific counting process. With the BATCH function active, the machine counts a preset number of bills and then stops counting when the batch number has been reached, even if bills remain in the hopper. By default, pressing the BATCH button will set the batch size to 100, 50, 20, 10, Off. The batch size can be adjusted by pressing the +1/+10 or the BATCH button.

When the set batch amount is reached, the Kolibri Domino will automatically stop and a "BATCH COMPLETE" message will be display on the screen alongside the number of bills counted. When the stacker is emptied, the machine will automatically continue to count up to the preset batch amount to create another batch.

If the hopper runs out of bills before a batch is completed, the machine will display "INCOMPLETE BATCH" on screen. At this point, the user may add bills to the hopper to complete the batch or remove the incomplete batch from the machine. To exit BATCH function, press again the BATCH button until "BATCH" disappears from the home screen.

#### 4.4 Add+Batch Function

This function batches the desired quantity of bills and monitors the running total at the same time. To activate this function, press the ADD and BATCH buttons separately, both icons should be displayed on the screen.

To exit ADD+BATCH function, press the ADD and BATCH buttons again separately.

## 5. AFTER-COUNT FUNCTIONS

### 5.1 Report

This function is available by pressing the REPORT button and provides an on-screen report of the total amount of each denomination counted, the value of the counted bills of that denomination, and a grand total value of all bills counted.

To exit the report screen, press the MENU button.

### 5.2 Serial Report

This function is available by pressing the REPORT button twice, it provides an on-screen report of each bill counted with its serial number and denomination.

To exit the report screen, press the MENU button.

### 5.3 Print

This Function is available by pressing the PRINT button while being on the report screen. If a printer\* is connected, a detailed printout of the counting report will be produced. Same is applied to get the report with serial numbers described in 5.2 Serial Report.

To connect a printer, use adapter cable provided. Insert one end of the adapter into the RJ11 Port (refer to 1.5 Views of the Kolibri Domino). The other end should be connected to the printer's cable.

*\*Printer sold separately*

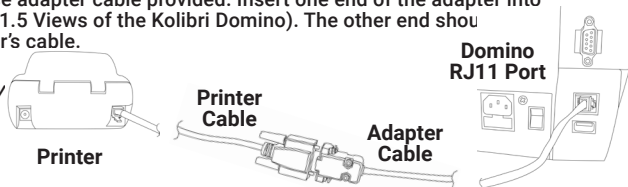

### 5.4 Menu

The Menu can be accessed by pressing the MENU button. To navigate up and down press MODE and CLEAR buttons, to choose a sub-menu press START/STOP button. To go back to main menu screen or home screen press MENU button.

Description of the Menu:

Menu	Description
1. SETTINGS	Include main settings options like Speed, Auto/Manual Start, Beep, Date & Time, Printing, Interface Color, Display Brightness, Sleep Mode.
2. DETECTIONS	Activate or deactivate serial number recognition, printer connection and detection features like Magnetic "MG", Dimension "DD", Double "DB", Ultraviolet "UV", Double "DB", Infrared "IR" and etc.

Menu	Description
3. MODES	Activate or deactivate the modes (COUNT, MIX, SORT, VSORT) that can be used from the home screen. When the mode is "ON", this mode can be selected from the home screen. When the mode is "OFF", it cannot be selected. Use START button to switch "ON/OFF".
4. SERVICE	Provide the option to update and calibrate the unit change the detection level, set and change the data as well as reset to the factory settings.
5. PRODUCT INFO	Display information about the product and the software version.

## 6. MAINTENANCE AND TROUBLESHOOTING

### 6.1 Maintenance

**ATTENTION:** The unit should always be turned off and disconnected from its power cord before cleaning. DO NOT use solvents such as thinner, alcohol, etc. to clean the machine.

Most operational problems can be avoided by regular care and preventative maintenance. Taking regular care of the Domino will significantly increase its lifetime.

To avoid problems, make sure there are no metal clips or rubber bands in the bills being counted. Be sure to follow the proper procedure for loading the hopper, refer to section 2.2 **LOADING THE HOPPER.**

For best results, it is recommended to use an air duster and a soft bristle brush to remove any dust or debris from the interior of the unit. When not using the machine for an extended period, cover it with the dust cover (not included with the unit) to prevent dust from settling inside.

All parts of the Kolibri Domino need daily care and cleaning. Pay close attention to the sensors, which are delicate components. If any dust or other foreign matter adheres to the sensors, it may cause various problems during operation of the machine.

1. Hopper Sensor
2. Stacker Sensors
3. Upper Sensors Block
4. Lower Sensors Block

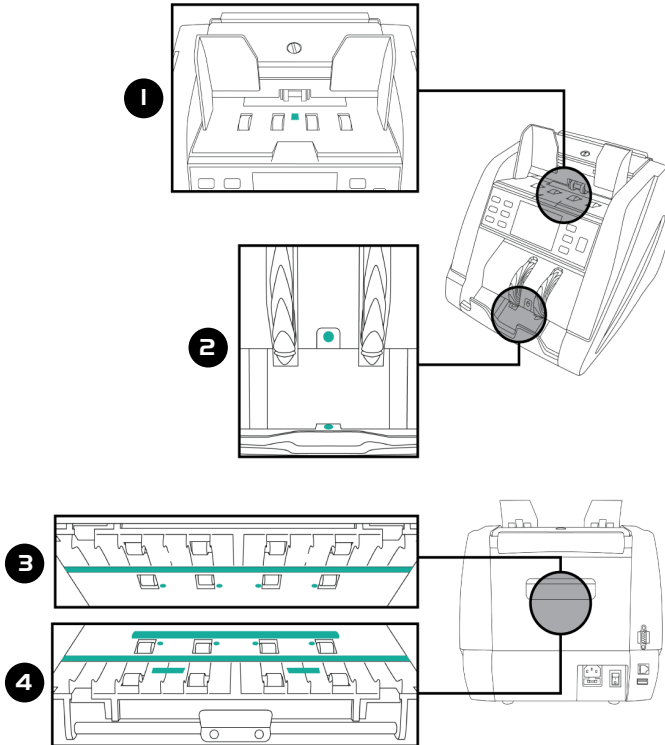

## 6.2 Adjusting Feed Gap

Sometimes, during the transportation or shipment of the unit, the adjustment of the feed mechanism may loosen. This can also happen during normal wear or tear and can lead to DOUBLE/CHAIN errors. The feed gap is the actual height of the bill feed path and should be tuned to just about the thickness of a single bill. If the feed gap is too wide, the user may experience a high amount of DOUBLE/CHAIN errors which are caused by more than one bill entering the scanning path at one time. If the feed gap is too tight, the unit may not be able to pass bills into the scanning path or catch on bills and tear them.

The following steps are the procedure for adjusting the feed gap:

1. Ensure the machine is turned off.
2. Position the rollers so that no teeth are visible. This can be done by manually turning the rollers until no teeth are showing and only the smooth section of the rollers is visible (see images below).

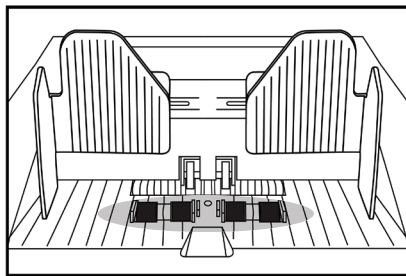
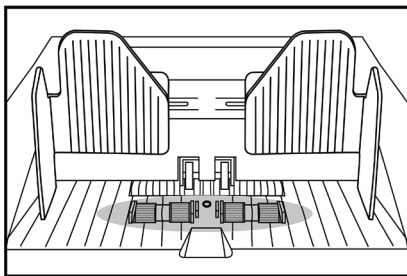

3. Place one bill that is crisp and rigid enough to prevent bending during the adjustment procedure. Place the bill lengthwise either to the right or left side of the hopper (See images below).

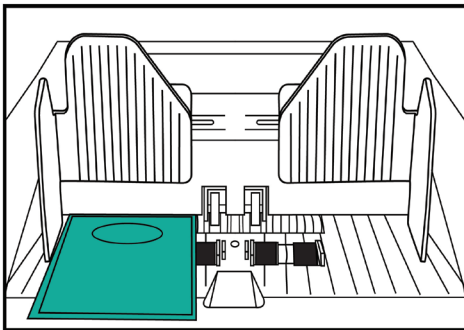

4. Guide the bill between the inner rollers during this step; you should feel moderate resistance as you move the bill back and forth through these rollers. In other words, the gap between these rollers is wide enough to pass just one bill per count, but narrow enough to feel a slight tension or friction when pulling the bill out.

To adjust the bill feed gap, use the instructions below to turn the adjustment screw at the top of the unit:

- a) Adjust the knob, slight turn at a time and then retest.
- b) If the bill feels too loose, tighten the feed gap by turning the adjustment screw clockwise.
- c) If the resistance against the bill feels too strong, loosen the gap by turning the screw counterclockwise.

**IMPORTANT NOTE:**

The Kolibri Domino's feed gap adjustment can be sensitive during adjustments. Do not overturn each adjustment or you may overshoot the optimum gap. We recommend testing with a stack of bills after each adjustment turn.

NEED HELP?  
SCAN QR CODE

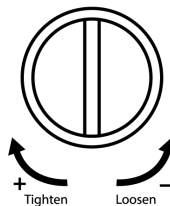

### 6.3 Calibration Procedure

The contact image sensors (CIS), Ultraviolet (UV) and Infrared (IR) sensors of the unit are calibrated properly from the factory. With regular, basic use, the sensor's sensitivity decreases which can lead to ID errors. To resolve this issue, the unit can be re-calibrated using the white calibration card that came with the unit.

Please follow the steps below to calibrate the sensor:

1. Ensure the machine is turned ON
2. Press MENU button, move down and select 4. SERVICE, when in SERVICE, select 2. CALIBRATION, when in CALIBRATION, CIS will be highlighted and instruction will be written on the screen.
3. Then turn the machine backside front.
4. Pull the back door handle to get access to sensor blocks. When inside, push the metal latch down to get access to upper and lower sensor block with CIS sensors. Put provided laminated calibration card between two sensor blocks. Bring the lower sensor block back to its initial position by pushing the metal latch down and lifting the lower sensor block. Make sure the lower sensor block is hooked back properly.

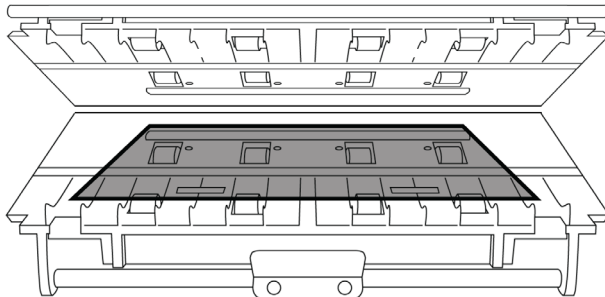

- To avoid malfunction caused by foreign objects, please clean your machine every day.
- Clean back door sensors with the provided bristle brush or a dry cloth frequently
- Clean inner sensors with the provided dry cloth frequently.
- Clean hopper and stacker sensors with the provided bristle brush or a dry cloth frequently.
- Rubber rollers may be cleaned with a slightly damp cloth. You may use a small amount of liquid soap on the cloth, but the soap residue should properly removed.

5. Carefully proceed to close the back door with the calibration card inside the machine.
6. Turn the machine face side to yourself and press START/STOP button to start the calibration process.
7. Calibration will begin and the calibration screen will display a message "CIS check wait"
8. When calibration is done "CIS check ok" message must be displayed on the screen. If "CIS check fail" message is displayed, calibration card must be readjusted and placed exactly on top of the CIS sensors and steps from 3 to 6 should be repeated.
9. When "CIS check ok" is displayed, remove the calibration card from the inside of the machine.
10. Reset the machine by turning it off, then on.
11. Same steps must be taken for the UV + IR calibration process.
12. The CIS calibration is done.

## 6.4 Troubleshooting

**NOTE:** The Domino, like all other discriminators on the market with intergrated detectors, cannot guarantee a counted bill to be genuine or counterfeit. There are several reasons a genuine bill may be recognized as counterfeit, or vice versa. Possible reasons include: direct sunlight exposure, worn bills, excessively dirty bills, or highly advanced counterfeiting techniques used to produce the bill. Separate equipment may be required to definitively determine whether or not a bill is counterfeit.

### Error message display:

Error Message	Cause	Solution
UV SUSPECT	Suspect bill detected by ultraviolet detection or UV detection issue	Remove top bill from stacker. This bill is not added to count. Press start to continue.
MG SUSPECT	Suspect bill detected by magnetic detection or MG detection issue	Remove top bill from stacker. This bill is not added to count. Press start to continue.
IR SUSPECT	Suspect bill detected by infrared detection or IR detection issue	Remove top bill from stacker. This bill is not added to count. Press start to continue.
IMAGE SUSPECT	Image of the bill is not genuine.	Remove top bill from stacker. This bill is not added to count. Press start to continue.
ID ERROR	Image of the bill is not recognized	Banknote tilt. Remove top bill from stacker. This bill is not added to count. Press start to continue.
DIFFERENT DENOMINATION	Denomination of the bill does not match	Machine in SORT mode. Different denomination detected. Remove top bill from stacker. This bill is not added to count. Press start to continue.

Error Message	Cause	Solution
SIZE SUSPECT	The size of the bill is not genuine.	Remove top bill from stacker. This bill is not added to count. Check size of the bill and make sure bill is not bent.
DOUBLE SUSPECT	The last counted bill is a double note or has double detections issue.	Ensure top bills in stacker are not stuck together. Remove all bills from stacker. Not added to the count total. Recount.
HALF NOTE	The last counted bill doesn't confirm size of the bill or the bill might be torn or folded.	Ensure top bills in stacker are standard size and or not folded. Remove all bills from stacker. Not added to the count total. Recount.
CHAIN ERROR	Two or more bills passed as one.	Ensure bills are loaded properly. Remove all bills from stacker. Not added to the count total. Recount.

#### Other error messages:

Error Message	Cause	Solution
LOWER LEFT COUNTING SENSOR	Issue with the lower left counting sensor	Clean the sensor. See section 6.1 Maintenance for location of sensors.
UPPER LEFT COUNTING SENSOR	Issue with the upper left counting sensor	Clean the sensor. See section 6.1 Maintenance for location of sensors.
ENCODER SENSOR	Issue with the encoder sensor	Restart the machine. Make sure rollers are turning and nothing prevents them from turning. If not resolved contact Kolibri technical service.
START SENSOR	Issue with the start sensor.	Clean the sensor. See section 6.1 Maintenance for location of sensors.
BACK DOOR OPEN	Back door not securely closed.	Ensure back door is closed. Press start to continue.

### Other possible errors continued:

### Other possible errors:

Problem Description	Cause/Action
Machine does not turn on	Ensure the power cord is connected properly. Check the fuse in the fuse compartment and replace it if necessary. Contact Kolibri's technical service center if the issue persists.
Machine fails to detect counterfeit notes	The sensors may have collected dust. See section 6.1 Maintenance for location of sensors.

## 6.5 Warranty

The Kolibri Domino is warranted for a period of 3 years from the date of purchase. In most cases a unit malfunction can easily be corrected by performing a thorough cleaning.

- Customer should allow the manufacturer the time and opportunity to test and diagnose the machine to determine warranty and non-warranty claims
- After receiving and unpacking the unit, customer shall keep the package and its user manual. Warranties are canceled in the event the device is transported in a non-original packaging or operation/maintenance conditions are not met

- Company is not responsible for unit malfunction due to improper maintenance, storage, or transportation including, but not limited to mechanical damage
- Manufacturer is entitled to introduce updated software, not described in the current user manual

#### **Non-Warranty Service:**

The manufacturer can perform maintenance and cleaning for an extra fee. For a non-warranty repair or maintenance quotation, contact our Technical Support team.

#### **Warranty service is not available in the following cases:**

- Cleaning of the unit from dust and mud
- Operation or maintenance rules requirements set in the user manual are not met
- There is mechanical damage to the unit or the sealed portions of the unit have been opened or tampered with
- There are foreign objects or liquid inside the unit

**The warranty does cover shipping to Kolibri's technical service center.**

## **6.6 Contact Information**

#### **Technical Support contact information:**

<http://kolibriusa.com/contact/>  
1-877-898-8750

#### **When contacting Technical Support, please have the following available:**

- Product Model – Located on the bottom of the machine.
- Serial Number – Located on the bottom of the machine.
- Nature of the problem – What happened, and when did it happen? Did the machine display an error message?
- Steps already taken to resolve the problem, and the results.

**Kolibri™**

©2022 Printed in China.

Specifications subject to change without notice.

[www.KolibriUSA.com](http://www.KolibriUSA.com)

FNDOMB050522